

Xplorer Motor Homes

Product of Startracks Technology

Contact: Bob Helvie
1227 W Beardsley Ave
Elkhart, IN 46514-2223
(574) 596-5331

STOCK # 1105

VIN # 1FDFE4F55BDA79992

Available for Immediate Delivery

- Year: 2011
- Capacity: 6
- Make: Sprinter
- Engine: Mercedes Diesel
- Transmission: Auto 5-Speed
- WB/GVW: 170" / 11,050 lbs.

Body Specifications:

- ◆ Mauck2 Personal Traveller
- ◆ 10" Wider Than a Standard Sprinter
- ◆ Up to 6'4" Interior Height
- ◆ Long Exterior Streetside Luggage Drawer
- ◆ Automated Entrance Step
- ◆ Kenwood AM/FM/CD/DVD/XM/GPS Dash Unit
- ◆ Rockford-Fosgate Subwoofer Speaker System
- ◆ iPad / iPod Hook-up in Driver Area
- ◆ Full LED Ceiling Lights with Multicolor Strips
- ◆ Bench Seat Converts Into a Bed
- ◆ Two Swivel Reclining Power Captains Chairs
- ◆ Driver and Co-pilot Seats Match Captains Chairs
- ◆ Aircraft Style Reading Tables
- ◆ Rear Marine Style Lavatory with Large Door
- ◆ Microwave, Refrigerator, and Sink
- ◆ In-Motion Satellite TV system
- ◆ XM Radio
- ◆ Dark Gray Rubber Tile Flooring
- ◆ Padded Vinyl Interior Walls and Headliner
- ◆ Trailer Hitch
- ◆ Interior Passenger Window Shades
- ◆ Large Rear Hatch-style Door w/ Rear Storage Area
- ◆ Power Sockets Throughout
- ◆ USB Hook-up to Convert TV to a Monitor
- ◆ 30,000 BTU Rear HVAC Heat-Cool System
- ◆ Individual Reading Lights
- ◆ Shore Power Exterior Connection

MAUCK2



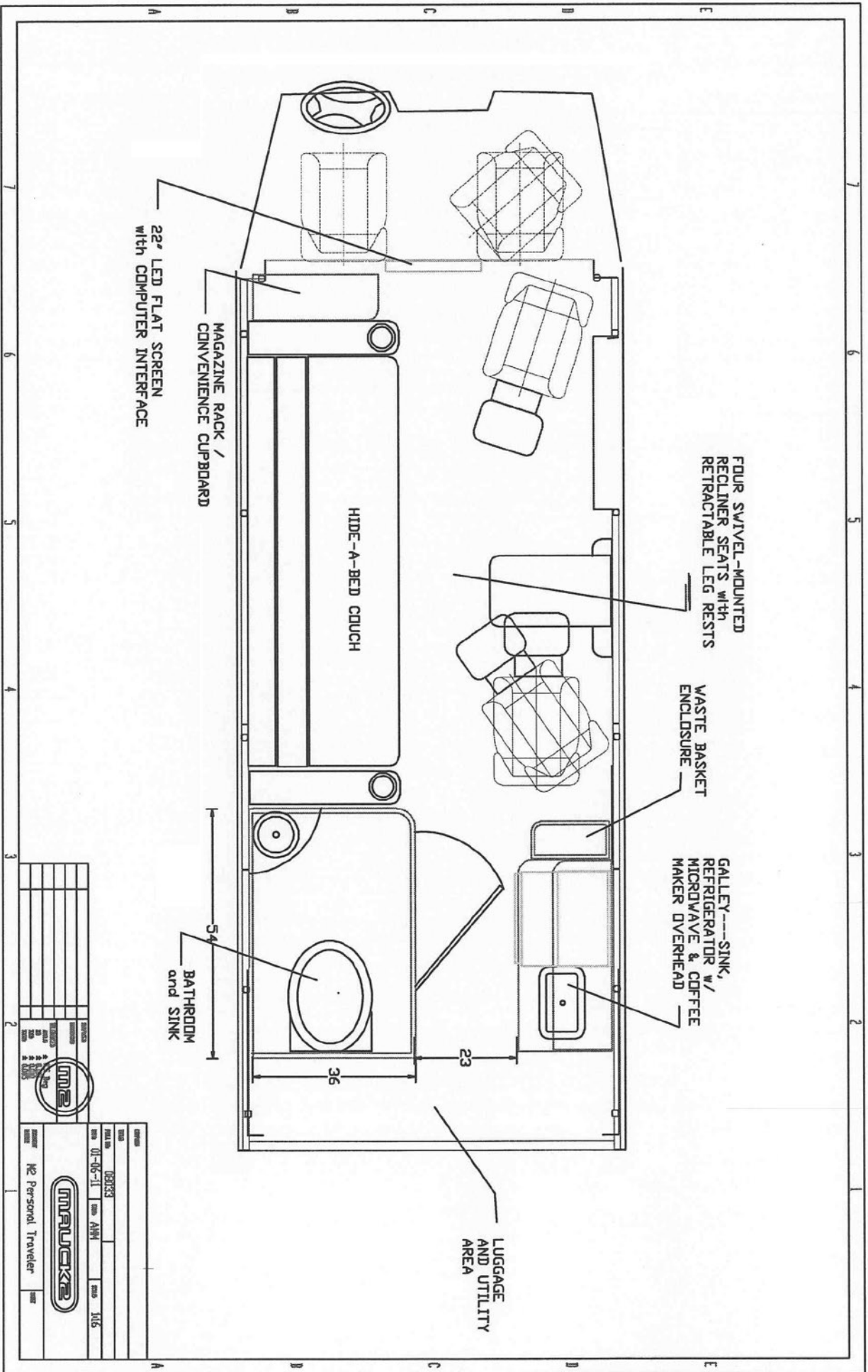

DATE	TIME	STATUS	REMARKS

MMR
 Motorhome Maintenance Record

MMR
 Personal Traveler

DATE: 08/03/23
 TIME: 01-05-21
 STATUS: AMM
 REPAIRS: 116